



# SLICE Technical Specifications



support@dtsweb.com

### SLICE MICRO Base



### SLICE NANO Base



#### Power:

- 7-15 VDC input voltage to entire stack via Base
- 100 mA maximum current draw
- Reverse current protection
- Remote power control input for turning unit on/off

#### Communication:

- USB from Base (Stack) to PC and module to module
- DTS software using Windows® XP, Vista

#### Trigger:

- Contact closure

#### Data Storage:

- 7 Gbyte non-volatile flash
- 120k samples/sec/channel maximum
- Recorder or circular buffer mode

#### Environment:

- 0 to 50°C operating temperature
- Rated to 500 g, 4 msec half-sine

#### System:

- One Base supports a maximum current draw of 1 A total per stack
- Sensor excitation shuts down when not recording
- Exceeds SAEJ211 response

### SLICE MICRO Bridge



### SLICE NANO Bridge



#### Three differential, programmable sensor channels:

- 2.5 or 5.0 V excitation via one 20 mA current-limited source per channel (voltage set at factory)
- ±2.4 V input range (2.5 V center)
- DC to 40 kHz bandwidth
- 1.0 to 1280 gain
- Auto offset range = 100% of effective input
- 16-bit SAR, one ADC per channel
- Software-adjustable, 5-pole Butterworth, low-pass, anti-alias filter (1 Hz – 40 kHz)
- ½ bridge and shunt emulation support
- 120 mA maximum current draw (depends significantly on sensor load)

### SLICE MICRO Accel



- 3 internal accelerometers
- Options from 50 to 2000 g
- 65 mA maximum current draw

### SLICE MICRO ARS



- 3 internal angular rate sensors
- Options from 300 deg/sec to 50000 deg/sec
- 75 mA maximum current draw

### SLICE NANO Stack Battery



- Charges whenever input power is connected to the Base
- ~15 minutes from complete discharge to full charge (10.5 VDC, 100 mA, at input connector on Base)
- Discharge rates:
  - ~16 seconds at 1 A
  - ~2 minutes at 400 mA

Specifications may be revised without notice.

Drawings not to scale.

**DOWN** connector\*\*



(looking into the connector)

Mating connector: DTS P/N S-MCP-12

Pin	Function
1	$\overline{\text{On}}$ (contact closure input to ground)
2	$\overline{\text{Start}}$ (contact closure input to ground)
3	$\overline{\text{Event}}$ (contact closure input to ground)
4	Status output (5 V via 10K with respect to ground)
5	7-15 VDC
6	7-15 VDC
7	Ground
8	Ground
9	USB_PWR
10	USB_DP
11	USB_DM
12	Ground

\*\* Both cables are 10 cm in length

**UP\*** connector\*\*



(looking into the connector)

Mating connector: DTS P/N S-MCS-12

Pin	Function
1	$\overline{\text{On}}$ (contact closure input to ground)
2	$\overline{\text{Start}}$ (contact closure input to ground)
3	$\overline{\text{Event}}$ (contact closure input to ground)
4	Status output (5 V via 10K with respect to ground)
5	7-15 VDC
6	7-15 VDC
7	Ground
8	Ground
9	USB_PWR
10	USB_DP
11	USB_DM
12	Ground

\* to PC

Channels 1, 2 and 3\*



(looking into the connector)

Mating connector: DTS P/N S-MCP-07

Pin	Function
1	+ Sig
2	- Sig
3	+ Ex
4	+ ID
5**	- Ex
6**	- ID
7**	Shield

\* Three connectors; cables 6, 10 and 14 cm in length

\*\* Pins 5, 6 and 7 are common

Channels 1-3\*\*\*



(looking into the connector)

Mating connector: DTS P/N S-MCP-16

Pin	Function
1	+ Sig (Ch 1)
2	+ ID (Ch 1)
3	- Sig (Ch 2)
4	+ Sig (Ch 2)
5	- Sig (Ch 1)
6	+ Ex (Ch 1)
7	- Ex (Ch 1)
8	+ Ex (Ch 2)

\*\*\* One connector; cable 10 cm in length

Pin	Function
9	+ ID (Ch 2)
10	+ Sig (Ch 3)
11	+ Ex (Ch 3)
12	- Ex (Ch 3)
13	- Ex (Ch 2)
14	- Sig (Ch 3)
15	+ ID (Ch 3)
16	- ID (Ch 1, 2, 3)/Shield



# SLICE NANO Mechanical Specifications



support@dtsweb.com

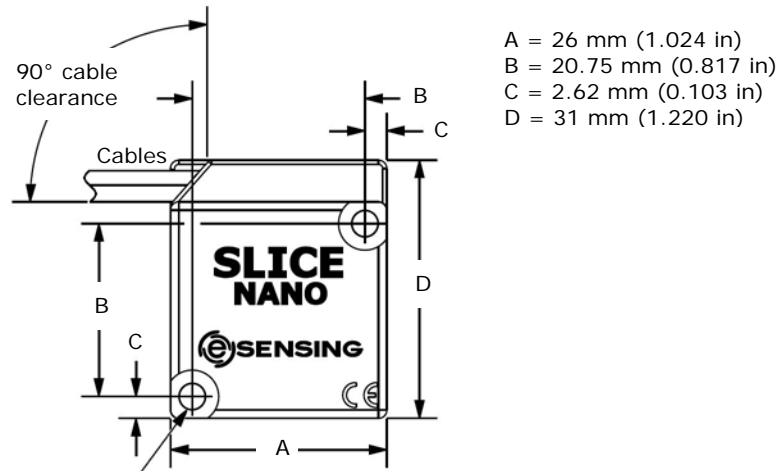

A = 26 mm (1.024 in)  
 B = 20.75 mm (0.817 in)  
 C = 2.62 mm (0.103 in)  
 D = 31 mm (1.220 in)

Ø3.2 mm (0.125 in) mounting thru holes x2  
 Accepts M2.5 (loose fit); 4-40 (free fit); M3 (tight fit)

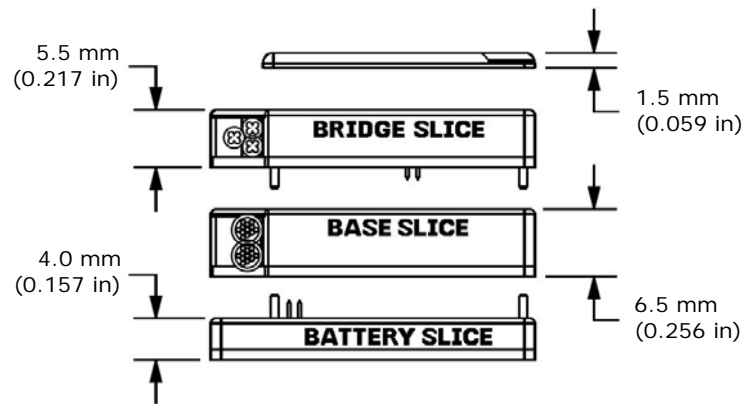

	Weight
Lid	~2.6 grams
Bridge (1 conn)	~12.6 grams
Bridge (3 conn)	~13.8 grams
Base	~14.2 grams
Battery	~7 grams

Total Stack Height mm (inch)	Mounting Screw Length (min) BH or SHC	
	M2.5*/M3**	4-40**
13.5 (0.531)	18 mm	3/4"
17.5 (0.689)	22 mm	7/8"
19 (0.748)	25 mm	1"
23 (0.906)	30 mm	1-1/8"
24.5 (0.965)	30 mm	1-1/8"
28.5 (1.122)	35 mm	1-1/4"
30 (1.181)	35 mm	1-3/8"
34 (1.339)	40 mm	1-1/2"
35.5 (1.398)	40 mm	1-3/4"
39.5 (1.555)	45 mm	1-3/4"
41 (1.614)	45 mm	1-3/4"
45 (1.772)	50 mm	2"
46.5 (1.831)	60 mm	2"
50.5 (1.988)	60 mm	2-1/2"
52 (2.047)	60 mm	2-1/2"
56 (2.205)	60 mm	2-1/2"
57.5 (2.264)	70 mm	2-1/2"
61.5 (2.421)	70 mm	3"
63 (2.480)	70 mm	3"
67 (2.638)	70 mm	3"

Specifications may be revised without notice.

Torque specs: \* 3.9 in-lb (0.44 Nm); \*\* 5.2 in-lb (0.59 Nm)