

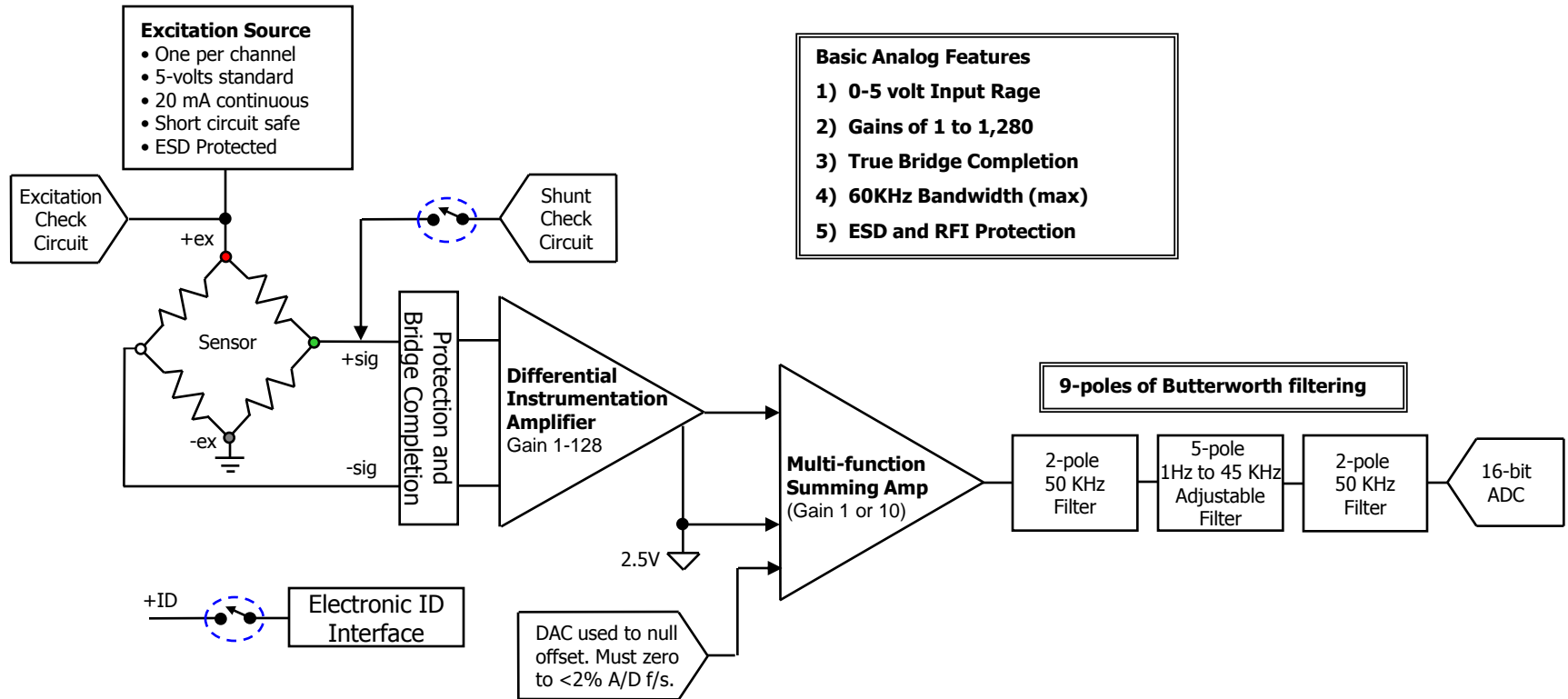

# **SLICE Bridge Sensor Connections**

# SLICE Bridge – Sensor Interface



# Standard 4-wire Bridge Connection

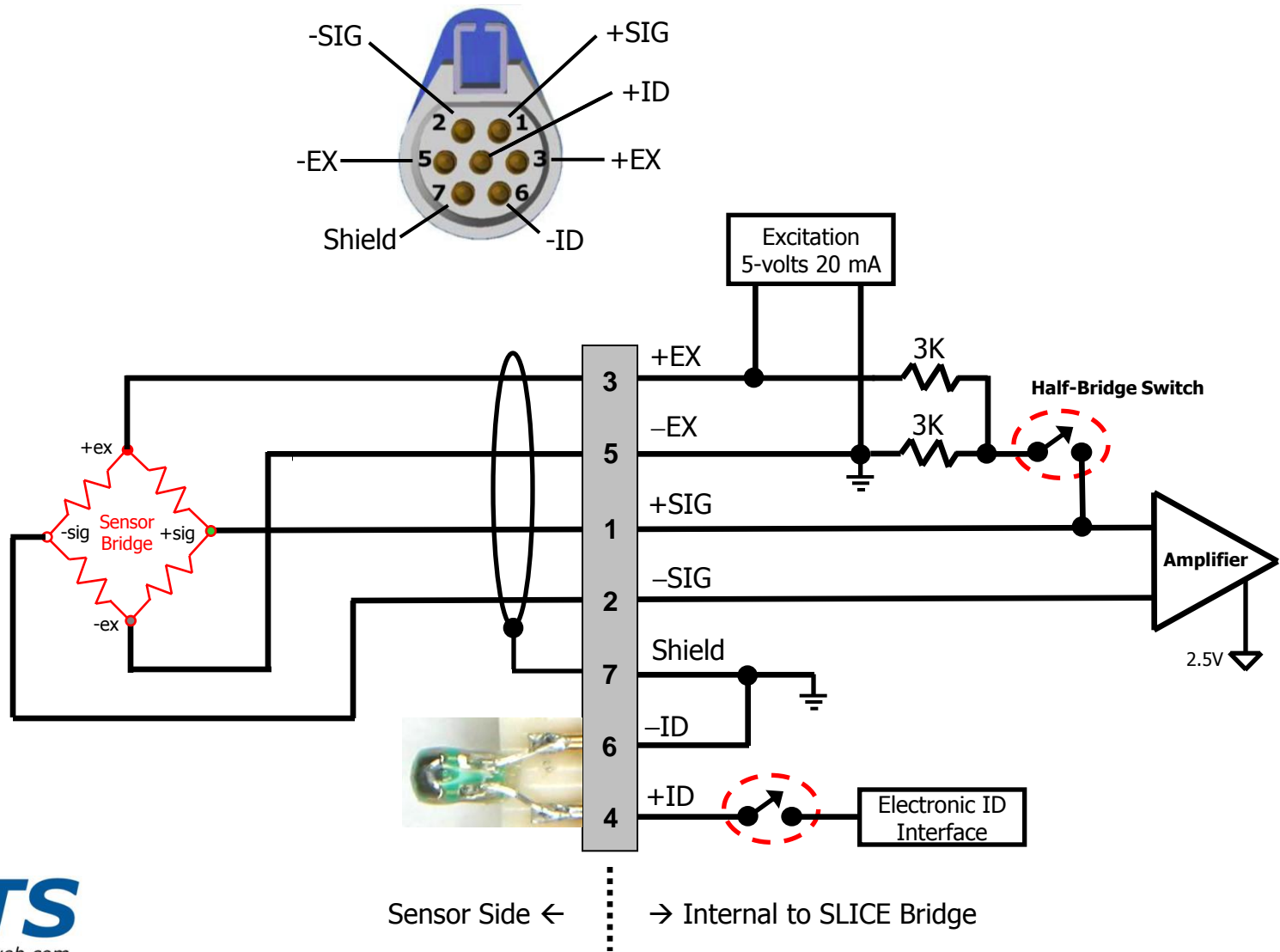

# Strain Gage 3-wire Connection

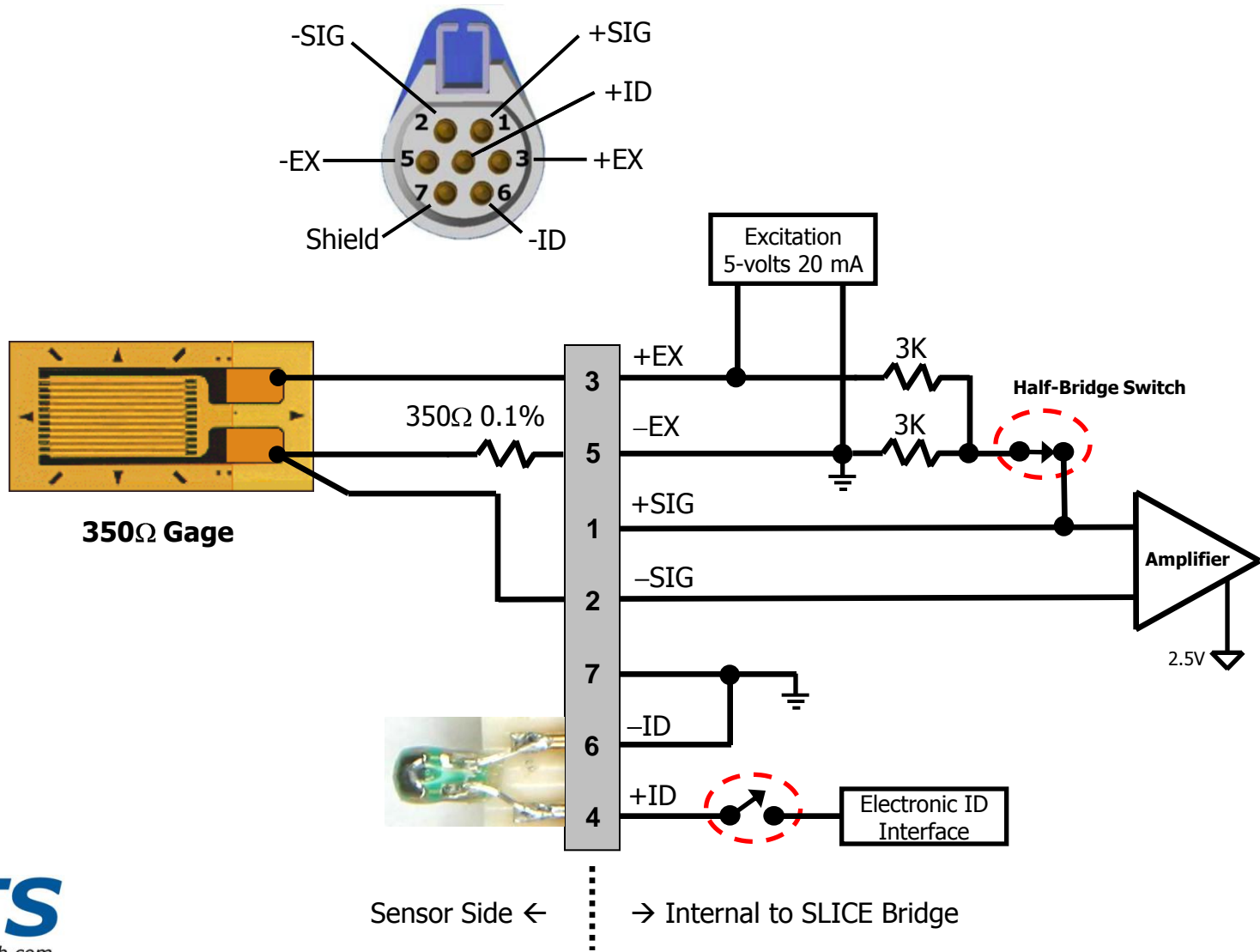

# Strain Gage 2-wire Connection

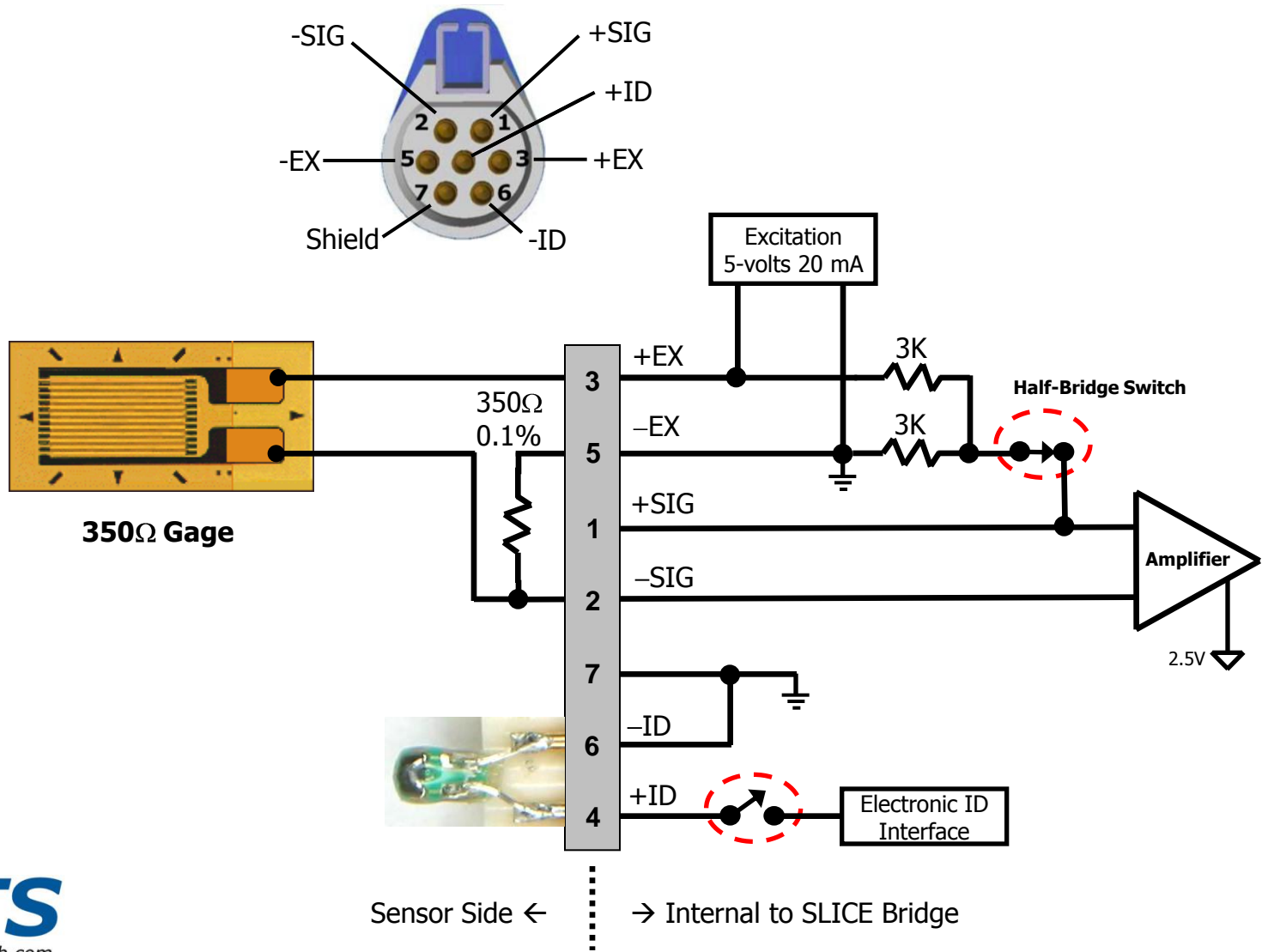

# Measuring Large Voltages - Example

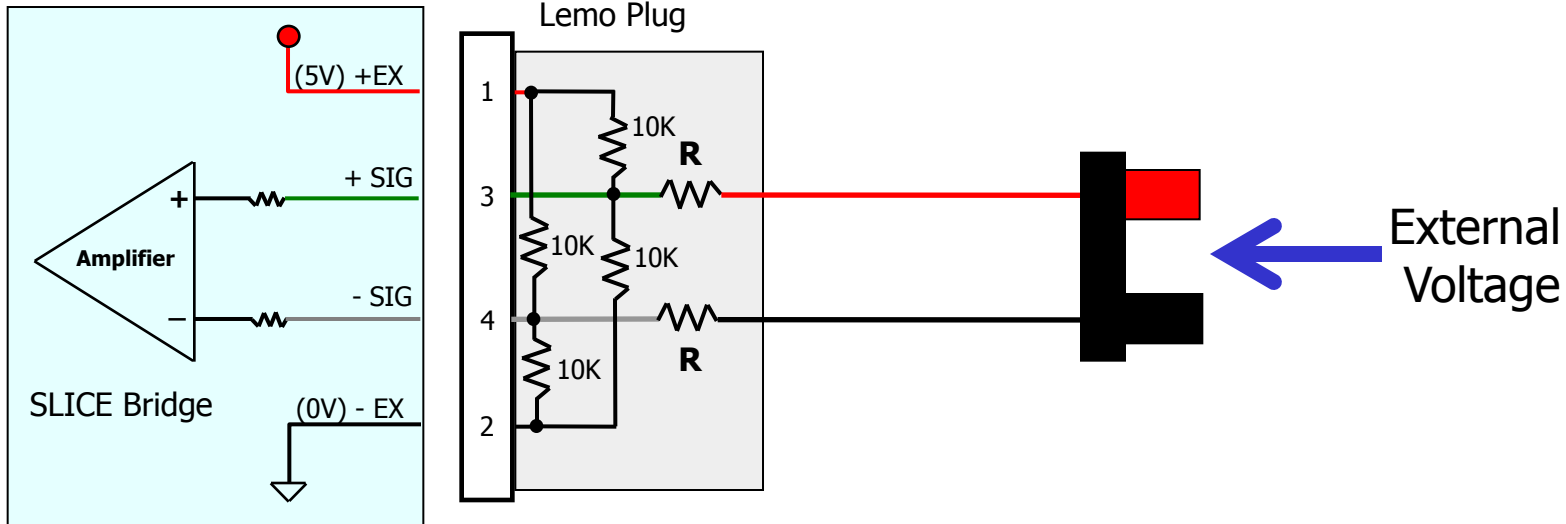

Approx MAX External Voltage <b>Vmax</b>	Resistance <b>R</b>	* Sensitivity mV/V
<b>+/-20V</b>	45.3K	99.404
<b>+/-40V</b>	95.3K	49.850
<b>+/-60V</b>	150K	32.258

\* Sensitivity calculation....

$$\left( \frac{5}{(5 + R)} \right) \times 1000$$